



SWIFT

2025 Challenger Exclusive



Your Home Anywhere



Welcome to Swift

UK's No.1 brand for leisure vehicles

We are the UK's largest leisure vehicle manufacturer, producing touring caravans, motorhomes, campervans and holiday homes.

We've grown from simple foundations back in 1964, when our founder Ken Smith built his first touring caravan, to become the UK's number one leisure vehicle brand.

Our philosophy is to build leisure vehicles that are at the heart of your holiday, whether that be nestled in the countryside or by the sea, searching out active pursuits or simply enjoying a quieter pace of life. With a lifetime of memories waiting to be made, it's time to find your ultimate caravan.



Contents

The Swift Difference	4	Practical bathrooms	20
SMART Construction	6	Exquisite extras	22
Introducing Challenger Exclusive	8	Features	24
Quick view	10	Technical specification	26
Designer looks	12	Swift Command	28
Relax and unwind	14	My Swift Life	30
Home from home cooking	16	Swift Owners Clubs	31
Premium comfort	18		

Introducing The Swift Difference

There's no better feeling than stepping into your caravan for a relaxing getaway. We've dedicated countless hours of research and development to ensure that every detail of your caravan is built to last and luxuriously comfortable, so you can get on with the important things in life – creating memories and enjoying unforgettable holidays.

Only when you choose Swift can you enjoy this exclusive package of benefits, as part of our Swift Difference.

Check out our guides,
articles and features!

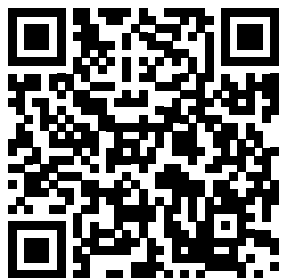

SMART construction

The UK's leading modern construction system with 'PURE' timberless framing that's impervious to water.



Efficient living

Swift caravans are engineered with efficiency at its core - from low energy LED lighting to an aerodynamic exterior for better fuel consumption and safer towing.



Long term warranties

Extra reassurance with multiple warranties including an industry leading 10 year bodyshell warranty.*

*Terms and Conditions apply



Supreme comfort

Enjoy an exceptional night's sleep with a Duvalay mattress fitted to all fixed beds and exclusive to Swift.



Expert training

Launched in 2015, The Swift Academy provides our employees with the opportunity to develop their skills at every stage of their career, encouraging our employees to reach their full potential. We have invested in the Swift Academy because we believe in our people and want to demonstrate our commitment to their development.



All year freedom

Swift caravans are tested to the extreme in a cold chamber to ensure they can keep you warm and comfortable whatever the weather.



Extensive choice

With over 20 models across our two Exclusive caravan ranges, there is a huge choice to suit most budgets and tastes at weights suitable for a variety of tow cars - all supported by the UK's largest dealer network. Many ranges have a selection of value-added extras to help you customise your caravan.



My Swift Life

My Swift Life provides owners with a unique personal profile, where you can access information that's specific to your caravan or motorhome, including; outstanding warranty claims, service information and a direct line into our Swift Customer Experience Team.



Pioneers

Innovation is our passion. We continually push the boundaries and utilise state-of-the-art design and construction techniques to ensure our products look sensational, work intuitively and function efficiently. Swift Command*, a product of innovative thinking, monitors and controls onboard systems via a user-friendly panel and smartphone app.

*Range specific



SWIFT

SMART

Standing the test of time with **Smart Construction**

As the trailblazer in the leisure vehicle industry, we have consistently raised the bar with our unwavering commitment to research and innovation.

Providing you with peace of mind, SMART is an ingenious blend of materials and construction techniques that guarantee enhanced structural integrity, improved insulation and all-important weather resistance - ensuring your investment will stand the tests of touring and help retain your caravan's residual value.



Strong

The strong timberless body frame uses 'PURE', a tough, hard polyurethane based product, that is totally impervious to water and has been proven through use.



Modern

SMART uses modern materials produced using cutting-edge technology and has been developed to ensure the exterior profiles maintain the modern desirable looks our caravans are renowned for.



Aerodynamic

We continue to lead the way in aerodynamics using Computational Fluid Dynamics to help shape the bodyshell for better fuel consumption and safer towing.



Resilient

Our side GRP outer and inner skins are more impact resistant than aluminium and can be easily repaired, ensuring long lasting good looks, securing your investment for the future.



Tested

Extensive safety and durability testing at the Millbrook track, and cold chamber testing down to minus 15°C and beyond puts prototypes through conditions most products will never have to experience in a lifetime.

PURe Polyurethane framework

The strong timberless body frame uses 'PURe', a tough, hard polyurethane based product that is totally impervious to water, ensuring the longevity of your caravan.

Polystyrene core

For ensured accuracy, lightweight polystyrene is cut to shape using the latest water jet technology. With 22mm polystyrene used in the side walls, and 28mm used in the roof, all Swift caravans meet the Grade 3 thermal properties needed for year-round adventures.

GRP

Manufactured at Swift, our GRP (glass reinforced plastic) front and rear panels are robust and resilient. The side panels feature outer and inner GRP skins of the same thickness to create a balanced panel which allows the caravan to expand and contract in different climatic conditions.

Unlike other manufacturers, our GRP inner skin does not use any jointing tape - all Swift caravans have a jointless sealing in the walls, and are embellished with wallpaper finishes.

Roof

The outer layer of the hail-resistant roof is fully bonded with woven white GRP. All Swift caravans are built with increased roof strength to allow for any additional features including air conditioning and satellite dishes (model specific).

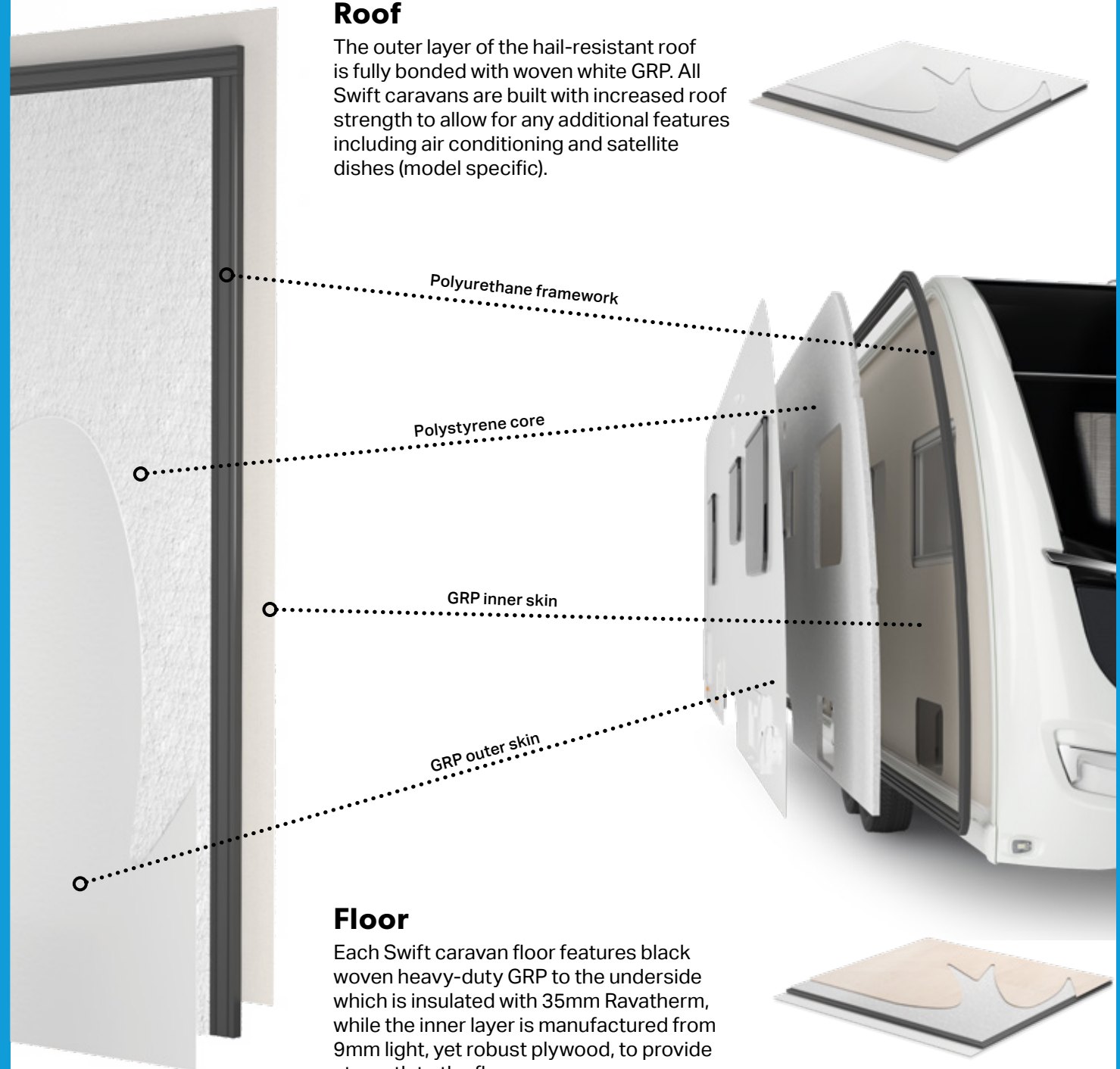
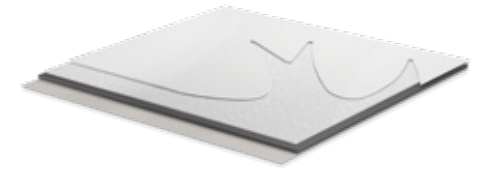

Floor

Each Swift caravan floor features black woven heavy-duty GRP to the underside which is insulated with 35mm Ravatherm, while the inner layer is manufactured from 9mm light, yet robust plywood, to provide strength to the floor.

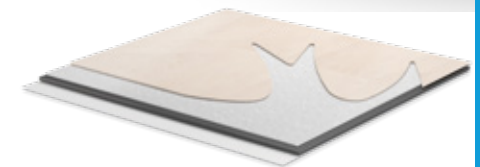

Introducing Challenger Exclusive

Challenger Exclusive is an enhanced version of Challenger, featuring additional premium features to make this range extra special.

Inside, Challenger Exclusive embraces sophistication with its sleek lines and impeccable finishes. In the lounge, the cushioning is wrapped in the stain resistant Willow soft furnishing scheme and finished with superior automotive stitching, whilst the latest in technology is at your fingertips for easy control of the onboard systems.

Outside, the enhanced exterior graphics and diamond cut alloy wheels not only showcase its exclusivity but also ensure that heads turn as you arrive at your destination.

With nine, two to six berth layouts to choose from, including layouts from the spacious 8ft-wide Grande range, there's a model tailored to every taste and preference.







Challenger

The much-loved Challenger, boosted with added extras, represents luxury at even greater value for money. Choose from four layouts, accommodating two to four people.



Challenger Grande

Enjoying all the desirable features of the Challenger Exclusive, but with extra room for even more relaxed dining and socialising. The extra width provides seven inches of additional space between the seats in the front parallel lounge, a larger front opening window, more storage space and a wider front bed.

Challenger Exclusive Quick View

* Estimate

480



Berths
2



Length
6.68m / 21'11"



Width
2.28m / 7'6"



MTPLM | Payload
1447kg* | 127kg

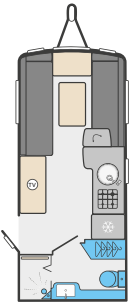

560



Berths
4



Length
7.63m / 25'0"



Width
2.28m / 7'6"



MTPLM | Payload
1650kg* | 160kg



580



Berths
4



Length
7.63m / 25'0"



Width
2.28m / 7'6"



MTPLM | Payload
1650kg* | 167kg



650



Berths
4



Length
7.98m / 26'2"



Width
2.28m / 7'6"



MTPLM | Payload
1785kg* | 160kg



560 L Grande



Berths
4



Length
7.63m / 25'0"



Width (8ft wide)
2.45m / 8'0"



MTPLM | Payload
1713kg* | 157kg



580 Grande



Berths
4



Length
7.63m / 25'0"



Width (8ft wide)
2.45m / 8'0"



MTPLM | Payload
1679kg* | 157kg



635 Grande



Berths
4



Length
7.98m / 26'2"



Width (8ft wide)
2.45m / 8'0"



MTPLM | Payload
1857kg* | 160kg



650 L Grande



Berths
4



Length
7.98m / 26'2"



Width (8ft wide)
2.45m / 8'0"



MTPLM | Payload
1831kg* | 160kg

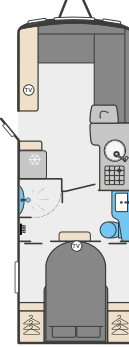

670 Grande



Berths
6



Length
7.98m / 26'2"



Width (8ft wide)
2.45m / 8'0"



MTPLM | Payload
1870kg* | 180kg

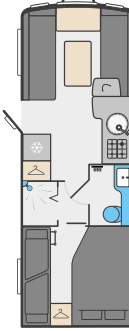

Designer looks

Stylish exterior

Streamlined aerodynamic profile with GRP bodyshell, and complete with exclusive graphics and a stylish grey side wall décor.

Diamond alloy wheels

Full diamond cut Edge alloy wheels for a refined look.

Awning light

For extra light at night, awning lights are fitted to both the nearside and offside.

External amenities

External 230V mains socket, BBQ point and connector, TV point, and cold water shower point (twin axles). Plus, **NEW** 120W solar panel for off-grid adventures.

LED lighting

Exclusive LED rear light clusters, LED high level marker and brake light to provide better visibility in poor weather.

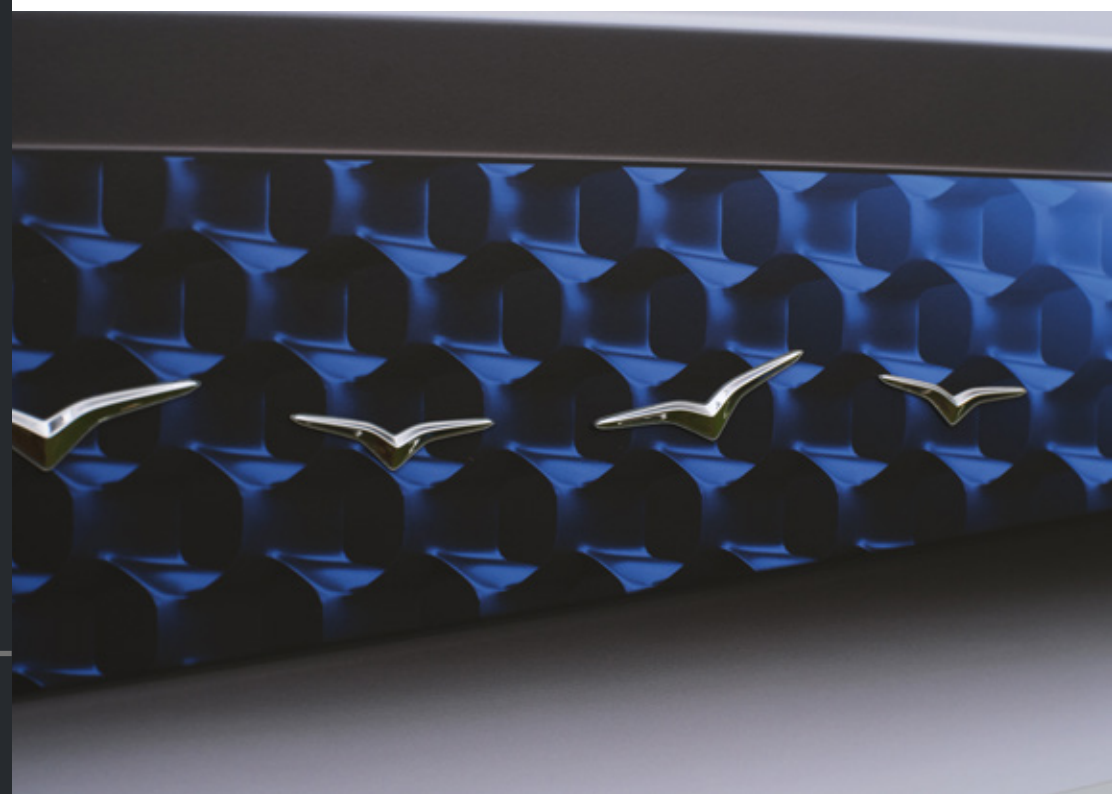



Relax and unwind

Comfy living

Willow soft furnishing scheme finished with superior automotive stitching, and Sangallo Elm woodgrain with Grau and Tora Tela features. Plus, six **NEW** scatter cushions.

Stylish curtains

Stylish curtains to front windows complemented by soft furnished wall pads.

More space

Challenger Grande Exclusive features a spacious front lounge with an extra seven inches between seats (compared to Challenger Exclusive).

Plentiful storage

Useful front chest featuring a soft close drawer and convenient slide-out extending top. Plus, upper lockers are fitted with **NEW** soft close hinges.

TV point

TV point(s) with 230V, 12V and aerial sockets.

Scratch resistant floor

Grey French Oak effect, high impact, scratch resistant floor.

LED lighting

Low energy LED lighting throughout, including under counter lighting in the kitchen.





Home from home cooking

Improved kitchen layout

NEW L-shaped kitchen for increased storage and worktop space, plus **NEW** deeper beige stone effect worktop.

Fully equipped

Thetford thermostatic oven and grill with oven light, along with a three-burner gas hob and an electric hot plate, finished with cast iron frets. Plus, a flatbed microwave.

Fridge freezer

Dual hinged Dometic (Series 10) 133 litre fridge with a 12 litre freezer compartment.

Extractor fan

Draw out kitchen odours and steam with the **NEW** fitted extractor fan.

Extra touches

NEW Mini-Heki rooflight, soft close kitchen drawers and two pull-out wire baskets, ideal for storing fruit and vegetables.





Premium Comfort

Luxurious mattress

Exclusive Duvalay Duvalite Strato mattress, which includes a platinum support layer and reflex foam for superior durability while memory fibre increases airflow for a more comfortable sleep (fixed beds).

Extra touches

Fixed beds are fitted with a full height headboard and aluminium bed frames to maximise strength and storage space, plus **NEW** wooden bed base surround.

Wardrobes

Wardrobes with mirrored doors (mirrors model specific).

Easy access storage

External luggage door on both sides of rear island bed to access underbed storage (model specific).

Blinds and flyscreens

Four-sided pleated blinds and flyscreens to all windows.





Practical bathrooms

Washroom

NEW washroom design with Levato marble-effect work surface and additional lighting. Plus, **NEW** washroom carpet.

Power shower

Shower cubicle with Ecocamel Jetstorm showerhead with on/off button for a powerful shower that uses less water.

Toilet

Thetford toilet with electric flush and 18 litre wheeled waste tank.

Boutique touches

Stylish handleless furniture, chrome effect swivel spout vanity tap, additional towel ring*, shower hanging rail*, and towel rail above radiator*.

*Model specific





Exquisite extras

Swift Command

Control and monitor onboard systems with the 7" LCD Swift Command control panel.

Swift Command Tracker

For peace of mind, you can subscribe to the Thatcham Category S7 approved pro-active tracker to add extra security to your Challenger Exclusive.

Alde central heating

To achieve a Grade 3 thermal insulation rating for year-round comfort, Alde central heating and water heating is fitted, with radiators positioned behind furniture and in the washroom.

Integrated Wi-Fi

Stay connected with onboard 4G Wi-Fi.

Wireless charging

Recharge your phone on the wireless charging pad for a neater living space.

Panoramic sunroof

Panoramic front sunroof incorporating fully integrated curved blind system, recessed lighting and speakers for the branded FM/DAB radio.

Alarm system

Passive infra-red alarm system with tilt sensor and key fob operation.





Challenger Exclusive Features

Exterior & Construction

- European Whole Vehicle Type Approval ensures compliance with strict weight, dimension and safety regulations
- AL-KO galvanised steel chassis with Euro-axle
- Overall body width 2.28m/7'6" (Challenger Exclusive)
- Overall body width 2.45m/8'0" (Challenger Grande Exclusive)
- EN1645 Grade 3 classification for heating and thermal insulation confirmed by cold chamber testing
- SMART construction with GRP body panels:
 - Strong, moisture proof 'PURE' polyurethane timber-less framed body shell with polystyrene insulation core (25mm in sidewalls, 32mm in roof)
 - Robust balanced panel side walls with GRP outer and inner skin
 - 44mm 'sandwich' floor construction with GRP outer skin, ply upper and high rigidity Ravatherm core
 - Hail resistant exterior GRP roof, fully bonded for extra strength and flatness
 - Sweeping front panel in GRP with triple flush fitting opening windows and exclusive LED front marker lights
- Full height GRP rear panel
- Streamlined aerodynamic profile
- Contrasting grey GRP sidewall with stylish exterior graphics scheme including **NEW** front panel graphic detail
- Exclusive LED rear light clusters, LED high level marker and brake light which provide better visibility in poor weather
- LED side marker running lights
- LED awning light with key fob control
- Offside LED awning light
- Surface mounted impact resistant skirt system
- Full diamond cut Edge alloy wheels
- Steel spare wheel
- Wheel lock(s)
- Heavy duty corner steadies
- Rain guards
- High tyre rating - a load margin is included in the tyre specifications
- High quality jockey wheel
- 13-pin Jaeger 12V car connector
- AL-KO Euro overrun device with two-way assisted handbrake
- AL-KO carabiner breakaway cable
- Shock absorbers for a smoother towing experience
- **NEW** black step-on hitch cover for easy cleaning of front windows
- Chrome effect two part grab handles to front and rear
- **NEW** 120W roof mounted solar panel
- Truma mains waterline for connection to tap
- Aerial point in battery box for portable satellite dish connection
- 230V mains socket
- BBQ point and connector
- Cold water shower point (twin axles)
- TV point

- Exterior access battery box with mains electric inlet (battery not included)
- External service doors - access under nearside front bed and fixed beds (model specific)
- Carbon effect easy access gas locker door with single lever three point locking
- Bulkhead mounted regulator suitable for use with either propane or butane bottles
- Fully double-glazed opening windows
- Screen printed windows with graphite grey tint
- Semi-recessed body colour awning rail on both sides
- Fixing bars for optional Thule rear mounted cycle rack (Elite G2)
- Grey exterior one-piece door with magnetic stay, interior moulded liner, chrome handle, window with blind, and bin with dust pan and brush
- Entrance step

Living, Relaxing & Sleeping

- 1.95m (6'5") headroom
- Willow soft furnishing scheme
- Sangallo Elm woodgrain with Grau and Tora Tela features
- Upper locker doors featuring Sand Grey panelling and chrome detailing with **NEW** soft close hinges
- Grey French Oak effect, high impact, scratch resistant floor vinyl
- Large retained embroidered entrance mat
- Panoramic front sunroof incorporating fully integrated curved blind system, recessed lighting and speakers
- Luxury curtains to front windows complemented by stylish wall pads (except washroom and bunk bed areas)
- Twin curtain track for improved hanging and ease of use
- Sectioned removable and bleachable carpets for flexibility
- Six scatter cushions
- Seat and backrest ventilation boards
- Beech slat seat and bed bases for extra comfort with sprung hinged tops for easy access (Challenger Exclusive)
- Bed make-up system with slats retained on track (Challenger Exclusive)
- Easy Accuride bed make-up system on front beds with beech slat seat and bed bases with fully opening hinged tops for extra comfort and easy access (Challenger Grande Exclusive)
- Exclusive Duvalay Duvalite Strato mattress, which includes a platinum support layer and reflex foam for superior durability while memory fibre increases airflow for a more comfortable sleep (fixed beds)
- Aluminium bed frames to maximise strength and storage space with **NEW** wooden bed surround (fixed beds)
- Full height headboards to fixed beds
- Wardrobes with mirrors (mirrors model specific)

- Midi-Heki rooflight with flyscreen and adjustable concertina blind in lounge
- Mini-Heki rooflights with flyscreens and adjustable concertina blinds in kitchens and bedrooms (model specific)
- Door flyscreen with easy concertina action
- Four-sided pleated blinds and flyscreens to all windows

Cooking & Eating

- **NEW** L-shaped kitchen for increased storage and worktop space
- **NEW** deeper beige stone effect worktop
- Thetford thermostatic oven and grill with oven light, plus three-burner gas hob and one electric hot plate, all with electronic ignition. Hob features cast iron frets and a glass lid with auto gas shut-off functionality
- Flatbed ventilated microwave oven with digital controls
- Dual hinged Dometic (Series 10) 133 litre tall slimline fridge with electronic ignition incorporating 12 litre removable freezer compartment
- **NEW** extractor fan
- **NEW** mini-Heki in kitchen area
- Soft close drawers
- Foldaway kitchen worktop extension
- Removable drainer and food grade nylon chopping board nestle together for easy storage in dedicated location
- Durable stainless steel kitchen sink with enhanced chrome effect swivel spout tap and unit

- Washing up bowl
- Kitchen acrylic splashback
- Two pull-out wire baskets in kitchen cupboard
- Two cutlery drawers on smooth-action steel runners (model specific)
- Chrome finish crockery rack
- Freestanding table

Washing

- **NEW** washroom design with Levato marble-effect work surface and additional lighting
- Shower bi-fold door retained on track for improved access (480, 580, 580 Grande 670)
- One piece 'Vellamo' shower cubicle with curved sliding door on **NEW** improved smoother running track (560, 560L, 635, 650 & 650L)
- Ecocamel Jetstorm showerhead with on/off button for a powerful shower that uses less water
- Chrome effect swivel spout vanity tap
- Restyled handleless furniture
- Thetford toilet with electric flush and 18 litre wheeled waste tank
- **NEW** removable bleachable washroom carpet
- Midi-Heki rooflight (model specific)
- 31mm thick washroom door with domestic style lock and handle
- Washroom additional towel ring (model specific)
- Washroom shower hanging rail (model specific)
- Towel rail above radiator (model specific)
- Washroom storage shelf (480 & 580)

Storage

- Double sided luggage door to access rear island fixed bed (560, 560L, 650 & 650L)
- Useful front chest featuring a soft close drawer and convenient slide-out extending top
- Positive overhead locker catches for secure storage on the move with chrome handles
- Upper front corner opening lockers for extra storage
- Seat bases featuring spaceframe construction with full front access and space for larger items
- Washroom storage units

Heating & Utilities

- Exclusive Swift Command control system with large 7" LCD colour touchscreen panel with improved user interface and functionality featuring;
 - Simple controls for monitoring and managing
 - Power
 - Battery selection, battery level meter and power usage
 - 230V AC load limiter (settable between 5 amps & 16 amps)
 - Solar panel charging levels (where fitted)
 - Heating control of Alde heating systems
 - Environment monitoring with internal and external temperature and internal humidity levels
 - Selected lighting control with soft-start dimming
 - Air-conditioning compatible with Dometic and Truma (dealer fit option, model dependent)

- Refrigeration control and monitoring via CI-bus connection
- Swift Command app with Bluetooth connectivity when with the vehicle, to manage and monitor key vehicle functions from your mobile device including power, heating and selected lighting
 - Swift Command remote feature to control and monitor when away from your vehicle (subject to Wi-Fi or GSM network coverage)
 - Includes the useful 'Places of Interest' feature including 'Campsites' from the Camping & Caravanning Club and Swift dealership locations
 - View location history along with system information
- Pre-installed Swift Command Tracker. Add Thatcham category S7 tracking for £100 per year
- On-board 4G Wi-Fi
- Alde radiator central heating and water heating with daily programming with LCD touchscreen control and choice of 1kW, 2kW or 3kW setting
- Digital programmable controller for heating and hot water
- Areas under beds and seats, and washroom areas warmed by Alde perimeter radiators
- On board 30 litre fresh water tank (twin axles only)
- High flow rate onboard pump with chrome effect taps for reliable, high performance water supply
- Onboard semi-rigid fresh water pipes

- Large bore underslung rigid waste pipes
- Isolation taps for gas appliances
- Fully protected mains electric system
- 25 metre mains hook-up cable
- 25 amp switchmode charger/transformer
- Wireless phone charging pad in lounge
- Low energy LED lighting throughout interior including:
 - Downlights in lounge
 - Under counter lighting in kitchen
 - Over locker lighting
 - Adjustable under locker LED spotlights with USB points
 - Illuminated pelmets above side windows
 - Strip lights above wardrobes
- A minimum of four 230V sockets throughout with twin USB points for easy charging of portable devices
- Chrome effect socket and switch surrounds
- Branded FM/DAB radio with USB, Bluetooth connectivity and auxiliary input
- Status 570 directional digital / analogue TV/ FM aerial and booster
- TV point with 230V, 12V and aerial sockets (multiple points in selected models)

Safety & Security

- Convenient one-key high security locks
- Dead lock facility on entrance door for added security
- VIN CHIP™ identification system concealed within construction to deter theft and aid quick recovery
- CRiS identity number labels on windows and caravan chassis
- Passive infra-red alarm system with tilt sensor and key fob operation
- AL-KO Automatic Trailer Control (ATC)
- AL-KO Secure wheel lock
- AKS 3004 stabiliser
- Side lift jack and brackets
- Smoke alarm
- Carbon monoxide alarm

Customer Service

- 10 year manufacturer-backed bodyshell warranty

Options







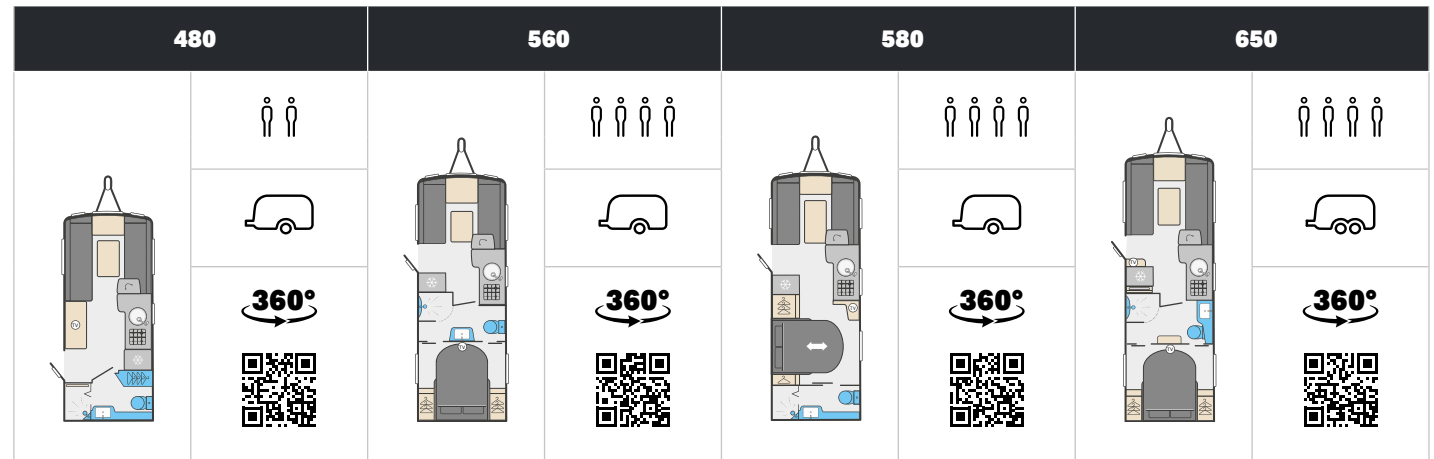

















Dealer fit

- Wrap-around front seating in addition to drawer chest
- Weight plate upgrade (model dependent)
- Roof mounted air conditioning unit (model dependent)
- Thule rail mounted rear cycle rack (Elite G2)

Challenger Exclusive Technical Specification



	480	560	580	650
Berths	2	4	4	4
Number of axles	1	1	1	2
Internal length (at bed box height)	4.98m / 16'4"	5.93m / 19'5"	5.93m / 19'5"	6.27m / 20'7"
Overall width#	2.28m / 7'6"	2.28m / 7'6"	2.28m / 7'6"	2.28m / 7'6"
Overall height (inc. TV Aerial)#	2.61m / 8'7"	2.61m / 8'7"	2.61m / 8'7"	2.61m / 8'7"
Maximum internal headroom	1.95m / 6'5"	1.95m / 6'5"	1.95m / 6'5"	1.95m / 6'5"
Overall length#	6.68m / 21'11"	7.63m / 25'0"	7.63m / 25'0"	7.98m / 26'2"
Awning A/A dimension	9.37m / 30'9"	10.32m / 33'10"	10.32m / 33'10"	10.59m / 34'9"
Mass in Running Order (inc. tolerance)	1320kg / 26.0cwt Est	1490kg / 29.3cwt Est	1483kg / 29.2cwt Est	1625kg / 32.0cwt Est
Maximum Technical Permissible Laden Mass	1447kg / 28.5cwt Est	1650kg / 32.5cwt Est	1650kg / 32.5cwt Est	1785kg / 35.1cwt Est
Total user payload	127kg / 2.5cwt	160kg / 3.1cwt	167kg / 3.3cwt	160kg / 3.1cwt
Personal effects payload	127kg / 2.5cwt	160kg / 3.1cwt	167kg / 3.3cwt	160kg / 3.1cwt
Factory fit options	0.0kg / 0.0cwt	0.0kg / 0.0cwt	0.0kg / 0.0cwt	0.0kg / 0.0cwt
Tyre size	195/70 R15C 104 R	195/70 R15C 104 R	195/70 R15C 104 R	185/60 R15 88 H
Thermal insulation grade	THREE	THREE	THREE	THREE
BED SIZES				
Front double	200cm x 186cm / 6'7" x 6'1"	200cm x 156cm / 6'7" x 5'1"	200cm x 168cm / 6'7" x 5'6"	200cm x 156cm / 6'7" x 5'1"
or front nearside single and front offside single	195cm x 67cm / 6'5" x 2'2" 186cm x 67cm / 6'1" x 2'2"			
Rear double		192cm x 133cm / 6'4" x 4'4"	185cm x 133cm / 6'1" x 4'4"	192cm x 133cm / 6'4" x 4'4"
Side fixed lower bunk				
Side fixed upper bunk				

Grande 560 L		Grande 580		Grande 635		Grande 650 L		Grande 670	
	   		   		   		   		   
4	4	4	4	4	4	4	4	6	6
1	1	1	1	2	2	2	2	2	2
5.93m / 19'5"	5.93m / 19'5"	5.93m / 19'5"	5.93m / 19'5"	6.27m / 20'7"	6.27m / 20'7"	6.27m / 20'7"	6.27m / 20'7"	6.27m / 20'7"	6.27m / 20'7"
2.45m / 8'0"	2.45m / 8'0"	2.45m / 8'0"	2.45m / 8'0"	2.45m / 8'0"	2.45m / 8'0"	2.45m / 8'0"	2.45m / 8'0"	2.45m / 8'0"	2.45m / 8'0"
2.61m / 8'7"	2.61m / 8'7"	2.61m / 8'7"	2.61m / 8'7"	2.59m / 8'6"	2.59m / 8'6"	2.59m / 8'6"	2.59m / 8'6"	2.59m / 8'6"	2.59m / 8'6"
1.95m / 6'5"	1.95m / 6'5"	1.95m / 6'5"	1.95m / 6'5"	1.95m / 6'5"	1.95m / 6'5"	1.95m / 6'5"	1.95m / 6'5"	1.95m / 6'5"	1.95m / 6'5"
7.63m / 25'0"	7.63m / 25'0"	7.63m / 25'0"	7.63m / 25'0"	7.98m / 26'2"	7.98m / 26'2"	7.98m / 26'2"	7.98m / 26'2"	7.98m / 26'2"	7.98m / 26'2"
10.32m / 33'10"	10.32m / 33'10"	10.32m / 33'10"	10.32m / 33'10"	10.59m / 34'9"	10.59m / 34'9"	10.59m / 34'9"	10.59m / 34'9"	10.59m / 34'9"	10.59m / 34'9"
1556kg / 30.6cwt Est	1522kg / 30.0cwt Est	1522kg / 30.0cwt Est	1522kg / 30.0cwt Est	1697kg / 33.4cwt Est	1697kg / 33.4cwt Est	1671kg / 32.9cwt Est	1671kg / 32.9cwt Est	1690kg / 33.3cwt Est	1690kg / 33.3cwt Est
1713kg/33.7cwt Est	1679kg / 33.1cwt Est	1679kg / 33.1cwt Est	1679kg / 33.1cwt Est	1857kg / 36.6cwt Est	1857kg / 36.6cwt Est	1831kg / 36.0cwt Est	1831kg / 36.0cwt Est	1870kg / 36.8cwt Est	1870kg / 36.8cwt Est
157kg / 3.1cwt	157kg / 3.1cwt	157kg / 3.1cwt	157kg / 3.1cwt	160kg / 3.1cwt	160kg / 3.1cwt	160kg / 3.1cwt	160kg / 3.1cwt	180kg / 3.5cwt	180kg / 3.5cwt
157kg / 3.1cwt	157kg / 3.1cwt	157kg / 3.1cwt	157kg / 3.1cwt	160kg / 3.1cwt	160kg / 3.1cwt	160kg / 3.1cwt	160kg / 3.1cwt	180kg / 3.5cwt	180kg / 3.5cwt
0.0kg / 0.0cwt	0.0kg / 0.0cwt	0.0kg / 0.0cwt	0.0kg / 0.0cwt	0.0kg / 0.0cwt	0.0kg / 0.0cwt	0.0kg / 0.0cwt	0.0kg / 0.0cwt	0.0kg / 0.0cwt	0.0kg / 0.0cwt
195/70 R15C 104 R	195/70 R15C 104 R	195/70 R15C 104 R	195/70 R15C 104 R	185/60 R15 88 H	185/60 R15 88 H	185/60 R15 88 H	185/60 R15 88 H	185/60 R15 88 H	185/60 R15 88 H
THREE	THREE	THREE	THREE	THREE	THREE	THREE	THREE	THREE	THREE
194cm x 122cm / 6'4" x 4'0"	218cm x 168cm / 7'2" x 5'6"	218cm x 168cm / 7'2" x 5'6"	218cm x 168cm / 7'2" x 5'6"	218cm x 158cm / 7'2" x 5'2"	218cm x 158cm / 7'2" x 5'2"	194cm x 122cm / 6'4" x 4'0"	194cm x 122cm / 6'4" x 4'0"	218cm x 168cm / 7'2" x 5'6"	218cm x 168cm / 7'2" x 5'6"
								163cm x 70cm / 5'4" x 2'4"	163cm x 70cm / 5'4" x 2'4"
192cm x 143cm / 6'4" x 4'8"	187cm x 133cm / 6'2" x 4'4"	187cm x 133cm / 6'2" x 4'4"	187cm x 133cm / 6'2" x 4'4"	187cm x 133cm / 6'2" x 4'4"	187cm x 133cm / 6'2" x 4'4"	192cm x 143cm / 6'4" x 4'8"	192cm x 143cm / 6'4" x 4'8"	186cm x 122cm / 6'1" x 4'0"	186cm x 122cm / 6'1" x 4'0"
								183cm x 57cm / 6'0" x 1'10"	183cm x 57cm / 6'0" x 1'10"
								183cm x 57cm / 6'0" x 1'10"	183cm x 57cm / 6'0" x 1'10"



SWIFT

COMMAND

DEVELOPED WITH SARGENT

More control with **Swift Command**

Available with the Challenger Exclusive range, Swift Command monitors and controls the onboard systems via a touch screen panel and a smartphone app, so you can always be in control.

With the convenience of your mobile device, you can access the onboard interface using Bluetooth when near your caravan or via your internet connection when remote.

Swift Command enables you to track system levels such as power, temperature, and humidity, and monitor the location of your vehicle. You can even control the heating, activating it for a warm return on colder days.

The app also lets you set up notifications to keep you informed of important functions, such as battery levels, frost alerts and alarm status.

Head to the Apple or Android store and search for 'Swift Command'.

Download on the
App Store

ANDROID APP ON
Google play



For even greater peace of mind, you can subscribe to the Thatcham Category S7 approved pro-active tracker to add extra security to your vehicle.

Swift Command Tracker by Sargent is monitored by an approved monitoring centre which operates 24 hours a day 7 days a week and provides European coverage and direct police liaison. This system is ready for use, all you need to do is purchase a tracking subscription by visiting www.swiftcommand.co.uk or calling Sargent on 01482 881655.



Lighting

Create just the right ambience onboard with easily adjustable lighting settings.



Location and remote features

Connect to your leisure vehicle from anywhere to view its systems information and location.

Conveniently control and monitor your onboard services when away from your vehicle.



Water

Keep an eye on your precious water levels so you know in good time when to top-up.

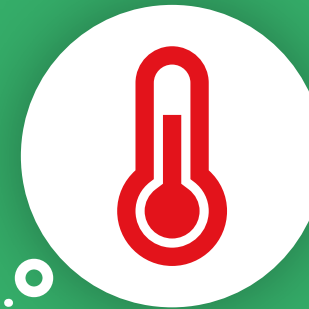

Heating

Activate whilst out exploring and enjoy the warmth when you get back.



Power

Track your energy use and manage your batteries for efficient use of your all important power services.



Fridge

Track your energy use and manage your batteries for efficient use of your all important power services.



SWIFT

My Swift Life

Get personal with **My Swift Life**

Replacing Connect Direct (our previous customer portal), My Swift Life is now available to all Swift caravan and motorhome owners*

My Swift Life provides owners with a unique personal profile, where you can access information that's specific to your caravan or motorhome, including; outstanding warranty claims, service information and a direct line into our Swift Customer Experience Team.

Log in to My Swift Life and report faults directly to Swift, enabling us to work together and allowing us to respond more quickly to your needs. Our new platform hosts a variety of information,

including product notifications, customer bulletins, product recalls and upgrades, as well as important notifications about our products and services.

Using My Swift Life, you can also view chargeable orders that have been placed on your behalf, by your Swift dealer or servicing provider, along with any outstanding warranty claims from the date of ownership.

What's more, you'll have access to useful tips and our comprehensive "How To" video library, designed to help you familiarise yourself with your Swift caravan or motorhome.

* Available to UK registered customers only.

Join My Swift Life for all this and more

- Access to useful "How To" video guides
- Access to personalised information 24/7
- Ability to report faults directly to our Customer Experience Team
- Authorised claims passed directly to dealer to speed up the warranty process
- Product upgrades notifications
- Live messaging direct into Swift's Customer Experience Team
- Upload service history records
- Useful bulletins and alerts

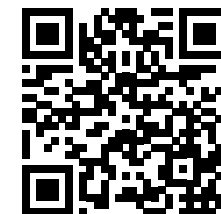

Find out more

Scan this QR code to see what My Swift Life has to offer

Join the Club!

Swift Owners Clubs

Swift Owners Club

The Swift Owners Club is the natural home for owners of Swift Group caravans and motorhomes. Our members come from all walks of life and include families, couples, single and retired people. Everyone, including pets, are welcome!

Joining our Club offers a host of social benefits and is probably one of the best investments you could make. If your caravan or motorhome is a brand owned by the Swift Group, or is an Airstream caravan (Model years 2017, 2018 or 2019), what are you waiting for?

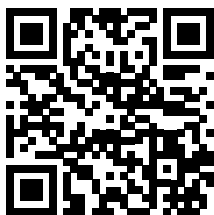

Join up!

Scan this QR code to find out more about joining the Swift Owners Club

Sprite Sterling Swift Owners Club

We are a small, non-profit-making organisation run by unpaid, subscription-paying members. Our activities centre around social rallies for owners of Sterling, Sprite and Swift caravans, dealer specials based on these and older caravans made by Eccles, Sprite Leisure Group or CI.

We organise temporary weekend 'pop up' sites (rallies) across the country. Many are on fields reserved for rallies.

Members get an exclusive invitation to visit the Swift Group factory every few years.

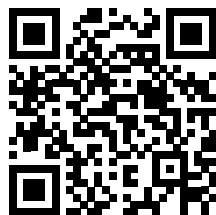

Join up!

Scan this QR code to find out more about joining the Sprite Sterling Swift Owners Club



Join the Swift community



Find out more at [swiftgroup.co.uk](https://www.swiftgroup.co.uk)

This brochure does not constitute an offer by Swift Group Limited (Swift). Swift reserves the right to alter specifications and prices at any time as materials and conditions demand. Distributors and dealers sell Swift products on their own account and not as agents of Swift. Accordingly, they have no authority to bind Swift or to make any representation or undertaking whatsoever on behalf of Swift. Please note, within this brochure, concept imagery may be used and therefore final specifications may be subject to change. Please confirm with your supplying dealer. All props are for photographic purposes only and are not included in the specification. Models shown may be fitted with optional extras. Issued September 2024.

